

T-bracket / double post bracket accessories

Static holder

SPECIFICATION

Types

- Type **R**: Clamping jaws at right angle to clamping arm
- Type **P**: Clamping jaws parallel to clamping arm

Steel C45
blackened
Cylinder head screws DIN 912
Centering bushings
Steel, blackened



INFORMATION

GN 869.2 T-bracket / double post bracket accessories have been designed for use with GN 865 (see page 1635) pneumatic fastening clamps.

T-bracket / double post bracket accessories are equally precisely positioned on the clamping arm as are the GN 872 (see page 1643) jaw block accessories on the holders themselves. Cap screws and centering guide bushing accessories are included.



TECHNICAL INFORMATION

- ISO-Fundamental Tolerances (see page A21)

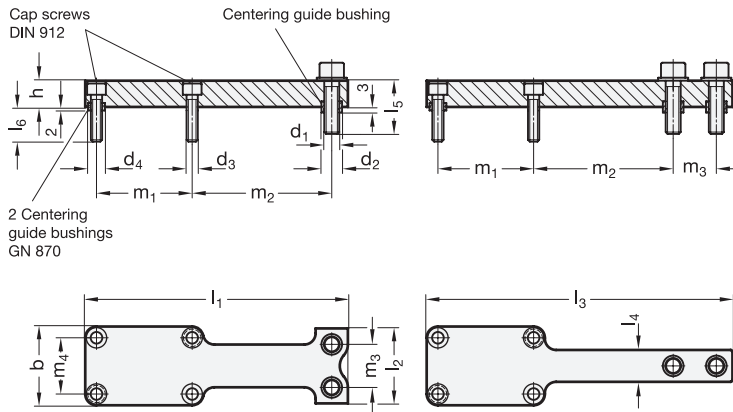

Mounting examples

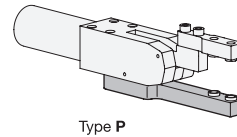
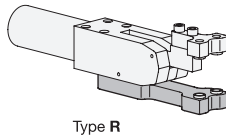

GN 869.2

Description	b -0.2	d1	d2 H8/h6	d3	d4 H8/h6	h	l1	l2	l3	l4	l5	l6	m1	m2	m3	m4	⚖
GN 869.2-32-P	32	M 6	9	M 5	7	10	-	-	115,5	13	18,5	8	34	53	17	22	150
GN 869.2-42-P	42	M 8	11	M 6	9	14	-	-	163	17	23,5	8,5	51	74,4	23	30	370
GN 869.2-52-P	52	M 10	13	M 8	11	16	-	-	198	20	28	12,5	62	88,5	30	37	720
GN 869.2-62-P	62	M 10	13	M 10	13	18	-	-	232,5	20	28	12,5	71,5	102	40	44	770
GN 869.2-32-R	32	M 6	9	M 5	7	10	98,5	30	-	-	18,5	8	34	53	17	22	150
GN 869.2-42-R	42	M 8	11	M 6	9	14	140	40	-	-	23,5	8,5	51	74,4	23	30	400
GN 869.2-52-R	52	M 10	13	M 8	11	16	168	50	-	-	28	12,5	62	88,5	30	37	900
GN 869.2-62-R	62	M 10	13	M 10	13	18	192,5	60	-	-	28	12,5	71,5	102	40	44	1030